

Storage

Entitlements:

Military members and civilian employees have the option to store their boat in accordance with the JTR.

The definition and size limitations identified under the Entitlement section also apply.

Out of Pocket Expenses:

Like shipping, the MGO is used to determine excess costs with one caveat of weight additive. Storage facilities are authorized to bill for weight additive. Weight additive is for larger items which utilize warehouse space typically designated for storage vaults.

This increased weight applies as follows...

Employee: Is not charged against authorized HHG weight allowance.

Military: Is charged against authorized HHG weight allowance.

Responsibilities:

- Prepare for storage; clean, drain fuel, disconnect the battery and remove drain plugs.
- Remove pilferable items such as clothing, televisions, skis, and similar items.
- Lower or remove all antennas, masts, fishing/trolling poles and outriggers.
- Ensure all charges are paid in full before pickup for boats located at a u-store it facility or marina.
- Ensure boat is ready on the date of pickup; if not, the TSP can charge you an attempted pick up fee.

Remember, when you are ready to ship you may incur excess cost, if you elect the government to coordinate the move.

Measurements

MEASUREMENTS REQUIRED

- Boat/trailer combined
- Boat/trailer separately

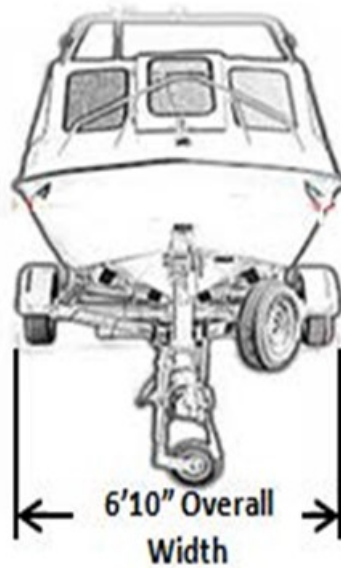
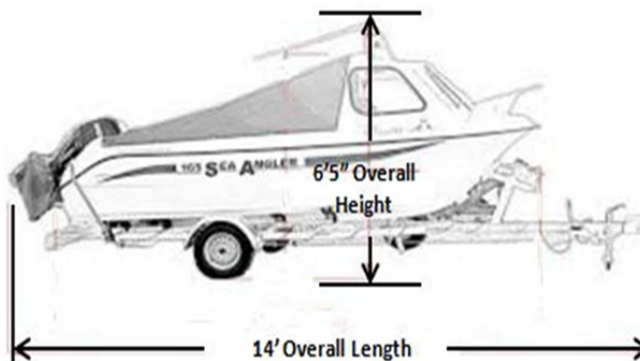

People First,
Mission Always

Shipping or Storing Boats



**Integrity First
Service Before Self
Excellence in all We Do**

**Air Force Personal Property
Activity Headquarters (PPA HQ)**

Entitlement...

Shipping boats is an entitlement outlined in the Joint Travel Regulation (JTR). Moving your boat can be costly; be sure you understand all costs before initiating movement.

Boats Defined (JTR):

Boat or personal watercraft, including jet ski, canoe, skiff, dinghy, scull, kayak, rowboat, sailboat, outboard or inboard motorboat and trailer.

Employee: Boat with or without trailer of reasonable size, limited to the size that will fit into a moving van; maximum size is 18 feet in length x 6 feet 10 inches in width, and height of 6 feet 5 inches. When a boat is the employee's primary residence, it is to be shipped as a mobile home.

Military: No size limitation for boat with or without trailer.

Customer Responsibilities...

- Provide boat/watercraft type, make, model, year, serial number, engine type, weight and dimensions; with associated trailer include its road worthiness, license#, state of issue, expiration date, dimensions and boat/trailer combined dimensions at time of application.
- Prepare to pay for all accessorial service charges such as; special packing, crating and handling.
- Remove pilferable items such as clothing, televisions, skis, and similar items.
- Remove all antennas, masts, fishing/trolling poles, and outriggers.
- Disconnect/reconnect all utilities and air conditioner.
- Ensure boat is ready on the agreed upon pick up date, if not the TSP can charge you an attempted pick up fee.
- Elect Shipment Method
 - Government Arranged
 - Haul-away: specialized TSP equipment used to transport boat on cradle, rack or flatbed. Normally designed for a large boat without or not roadworthy trailer.
 - Tow-away: TSP self-contained power unit used to pull boat on associated trailer.
 - Personally Procured
 - You make all arrangements and pay for services rendered; reimbursement and advance operating allowances are in accordance with JTR/Service regulations.

Out of Pocket Expense...

When determining out of pocket expenses, the government utilizes your Maximum Government Obligation (MGO) to determine excess cost.

The MGO is calculated using your maximum household goods (HHG) weight entitlement, regardless of weight shipped, to and from the authorized locations on your travel orders.

(Household goods sent will have move coordinated in conjunction with boat)

If you exceed your MGO, you pay the excess cost.

Your local Transportation Office will work with the Joint Personal Property Shipping Office to provide you with estimated charges. It is important to remember that they are estimates; exact amounts won't be known until the transportation bill is received.

Please remember if you elect to ship your boat and there were minimal or no excess charges, there may be charges on your next move.

Do your research before you make your decision to ship your boat.

Boats larger than 14ft x 6ft, 10in x 6ft, 5in or the destination is Alaska or overseas, one-time-only rather than standard rates must be sought by the Joint Personal Property Shipping Office through the U.S. Transportation Command.

